

The sweet
solution behind
your success.



Profitable chocolate dreams. Sweet perspectives.







The cocoa and chocolate industry has outstanding prospects for growth. The unique properties of chocolate as the food of the gods combine pleasure, health in a harmonic and esthetic manner. The global trend toward diversified chocolate consumption is opening up new markets. Which of them do you intend to conquer? And with which partner do you plan to shape this future?

The sweet solution behind your success

The Buhler Technology Group's Chocolate & Cocoa business unit has developed optimal solutions for the nut, cocoa, and chocolate industries for over 100 years. With the total knowledge and combined capabilities of Buhler, Barth, Frisse, and Bindler, Buhler offers a seamless range of products and services from the raw cocoa beans to the molded chocolate articles. Services cover everything from

the development and production of machines, process technologies, and control systems to the construction of complete turnkey production plants.

Buhler engineers develop individual solutions with you and for you which offer you high added value. This enables both small and large companies to share the innovation power and technological leadership of Buhler. A large number of successful companies place their confidence in Buhler as a solid partner who will support them throughout their lifetime with consulting, technology, development, project processing, and customer service.

Chocolate & Cocoa business unit	Bühler Barth GmbH D-Freiberg	Bühler AG CH-Uzwil	Frisse GmbH D-Bad Salzuflen	Bühler Bindler GmbH D-Bergneustadt
Cocoa processing for				
– chocolate production				
– cocoa powder production				
Nut processing				
Production of				
– chocolate masses				
– filling and fat masses				
Crystallization and molding				



The cocoa path.

Making the best out of valuable raw materials.

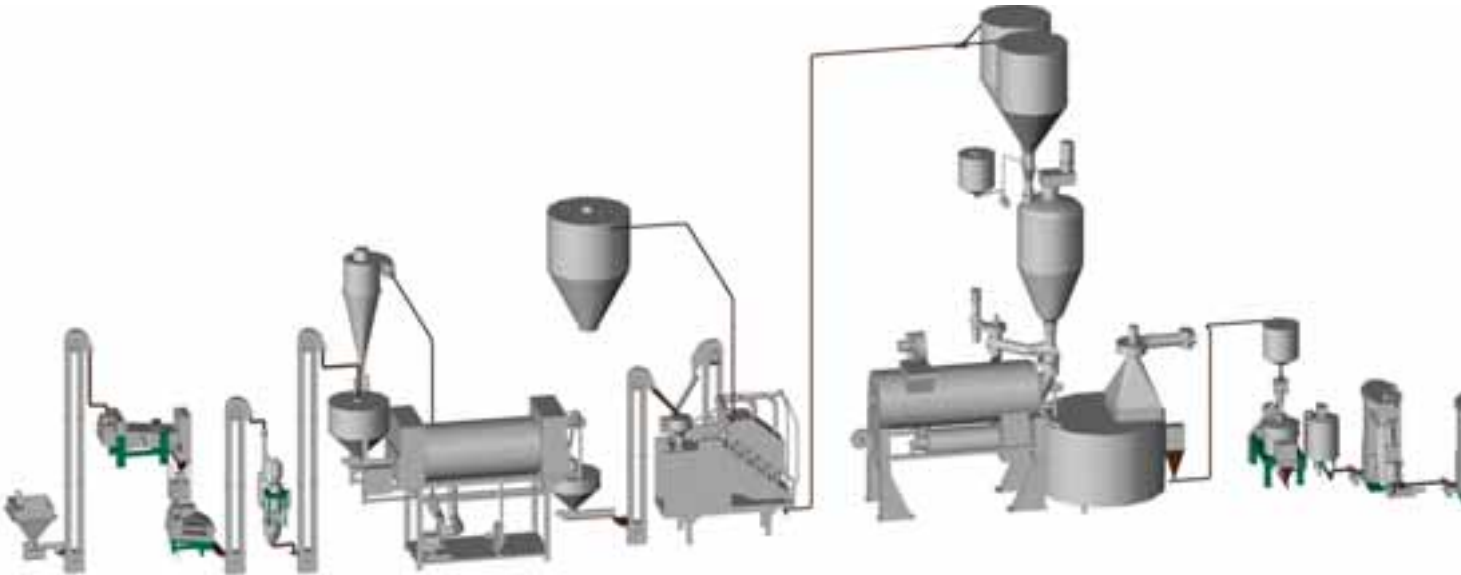

The NARS process

Commercial success in cocoa production is largely determined by the achievable yield of cocoa nibs. The NARS process (Nibs Alkalinizing Roasting System) developed by Barth enables the value-determining features of the semi-finished cocoa products – color, flavor, yield – to be optimally selected.

IR treatment and crushing

The raw and cleaned cocoa beans are treated before separation of the shells by infrared radiation (IR). On the one hand, this ensures easy and complete separation of the shells and cocoa nibs for achieving a maximum yield. On the other hand, migration of the cocoa butter to the shells is prevented. In the subsequent two-stage winnowing operation, the nibs are separated from the shells in a very gentle way, but with high efficiency.



Alkalinizing

Alkalinizing provides the basis for producing cocoa powder of excellent quality. Simple adjustment of the pH value and determination of the pressure-temperature-time process profile enables the color intensity of the finished cocoa powder to be varied from natural hues to deep brown, red or black shades.

Roasting

The controlled roasting atmosphere allows the flavor to be uniformly intensified. In the batch roaster, all time-temperature profiles can be selected to achieve optimal reproducibility. The injection of water or saturated steam slashes the germ count to below 1000 germs/g.



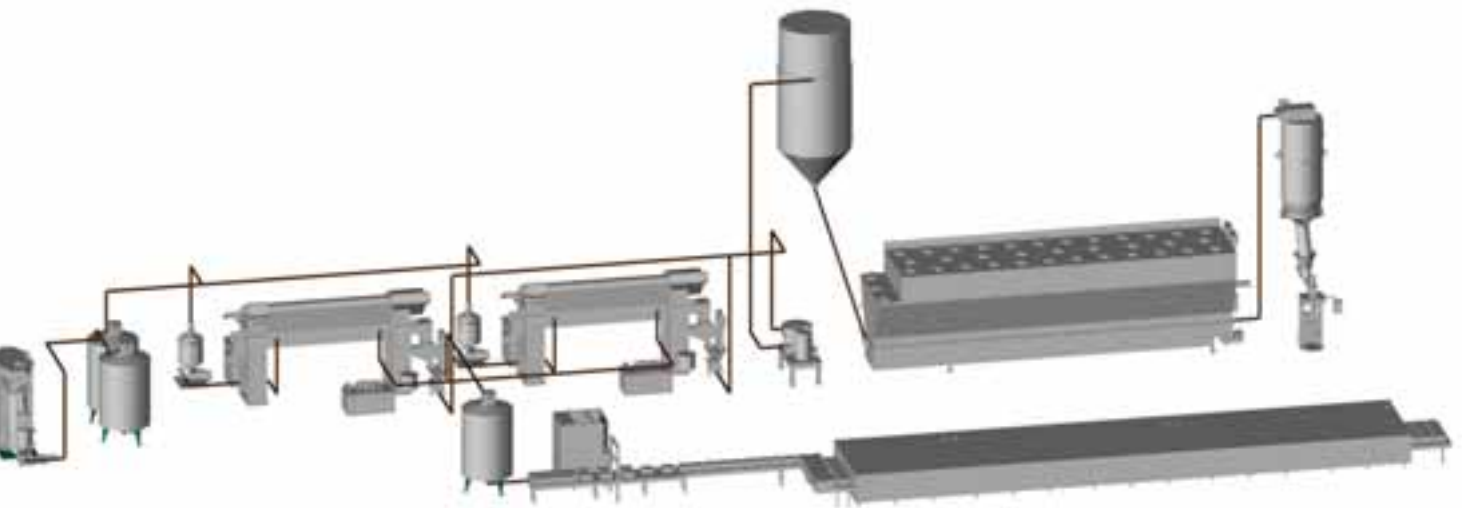

Grinding and pressing

The high shear forces applied in the two-stage grinding process allow cocoa masses to be produced with very low viscosities and a low particle size, which increases the throughput rate of the downstream hydraulic presses.

Precrystallization and block production

Cocoa mass before and cocoa butter after the pressing process can be reliably and efficiently shaped into blocks. These semi-finished products pass through a precrystallization stage based on the Seedmaster technology, in which minute, heat-resistant crystals are formed. This is the precondition for obtaining homogeneous and perfectly crystallized, glossy blocks at the end of the cooling line.



Cocoa powder production – grinding and stabilizing

Glossy cocoa powder with a saturated color and without lumps is the goal here. Complete cocoa butter stabilization with the creation of minute crystals for obtaining free-flowing characteristics is ensured by efficient heat transfer in a fluidized bed. Process reliability with easy access allows absolutely hygienic production conditions to be achieved.

From the preceding disagglomeration process of the cocoa press cake via classifier mill, the powder is carefully monitored to prevent sparking.







The chocolate path.

Perfect – gentle – uncompromising.

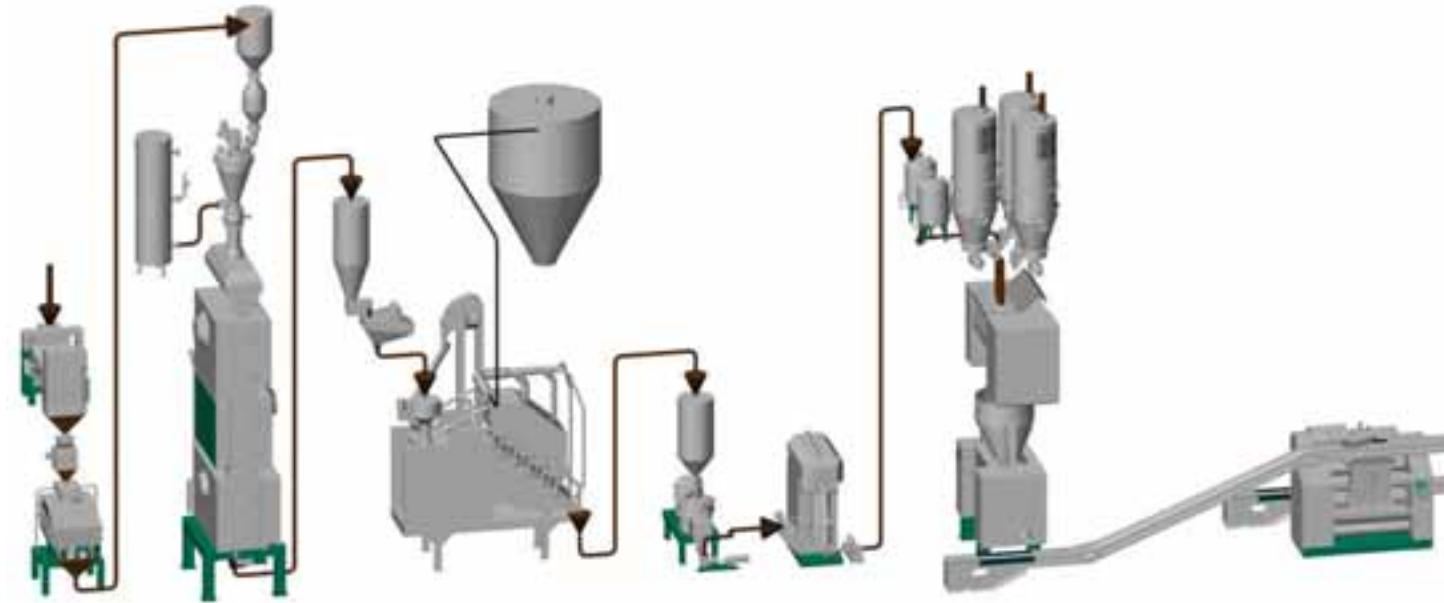

Cleaning

Quality assurance of chocolate starts with the cleaning of the cocoa beans. This important stage prevents impairment of the downstream processes and thereby contributes considerably to a high production system uptime.

Debacterization and roasting

Debacterization of the cocoa beans efficiently reduces the germ count while none affecting the flavor at all. In the roaster, flavor development of the beans is selectively promoted by gentle drying and roasting. The thermal processes can be configured as required, depending on the specific plant. Debacterized and roasted cocoa beans are easier to winnow, producing a higher nibs yield.



Winnowing

Gentle winnowing of the cocoa beans in two stages is the precondition for efficient separation of the shells and for maximizing the nibs yield. A total of seven measurement points allow the visual result of each bean variety to be fine-tuned and accurately reproduced.

Grinding

The nibs are ground in two stages into a cocoa mass with optimal flow characteristics. Thanks to the high and uniformly distributed energy density in the bead mill, masses are produced with a very narrow particle size distribution. The outstanding cooling characteristics of this machine are particularly beneficial in compound production.



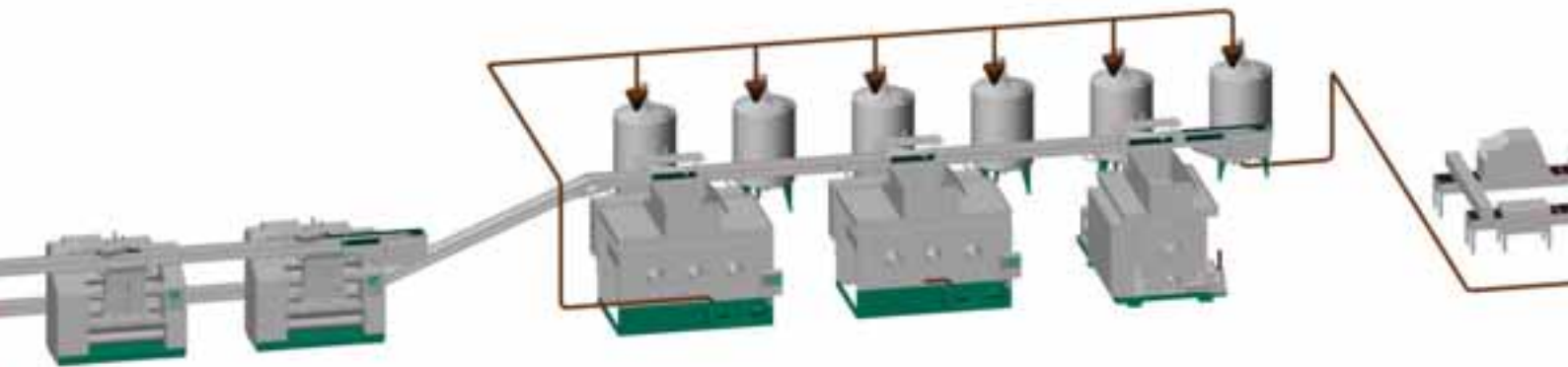

Product handling and feed

Gentle conveying and storage support the main processes to a considerable extent. Efficient and accurate product feed ensures high throughput rates and a reproducible quality.

Mixing and kneading

In the heart of the chocolate processing system, the chocolate recipes are produced. The ingredients are carefully mixed, with the high shear and kneading action producing homogeneous and plastic masses for further processing.



Refining

Constant fineness is a precondition for ensuring that chocolate will be a pleasure. The Buhler two-stage refining process has set new standards worldwide in terms of quality and efficiency. The flexible two-roll and five-roll refiners produce chocolate, filling, and coating masses in a wide variety of compositions and with uniform fineness.

Conching

In order to cover your specific end refining needs, we offer different conche designs. They allow optimal values to be achieved in terms of texture, sensory characteristics, and flavor as well as in terms of final moisture content, viscosity, and flow limit.



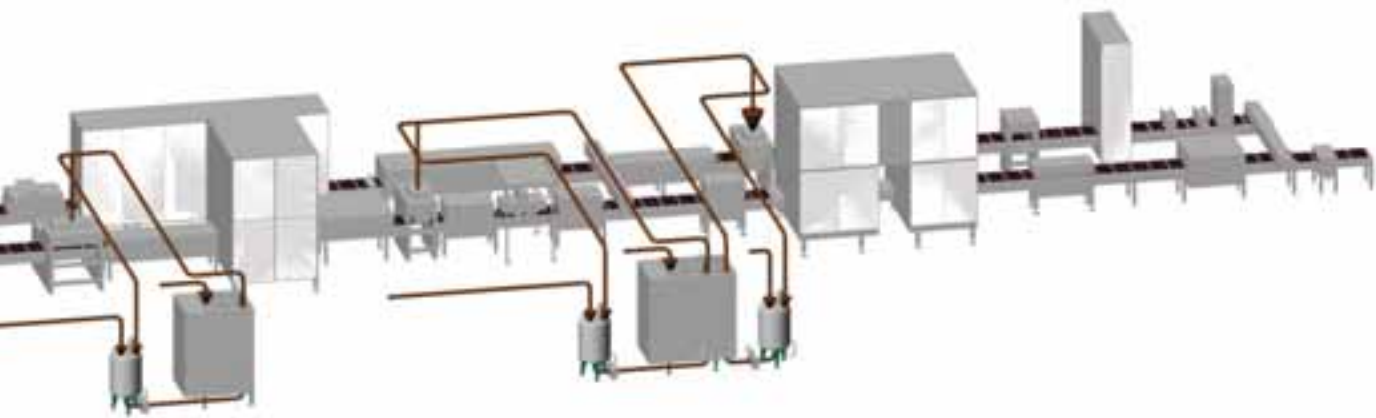

Precrystallization

Chocolate articles produced by the revolutionary Buhler seed precrystallization technology are distinguished by their appreciably improved gloss, their denser crystal matrix, and their higher strength. Fat bloom creation is substantially retarded, and storage stability considerably increased.

Depositing and molding

Innovative chocolate articles with accurate weights are produced with high efficiency on lines specified to fulfill your individual chocolate dreams in conjunction with technologies that can be selected from a wide variety of options. This allows your special solid products and hollow or filled articles to be produced either by the traditional molding, One Shot, or cold-stamping process in exactly the shape you wish.



Automation

To make high-quality products, trouble-free processes and complete retraceability of the production process are required. Buhler possesses the necessary know-how and can thus ensure an extremely high plant uptime.





The nut path.

Flavor – shelf life – constant quality.



Cleaning and grading

After a cleaning stage, hazelnuts and other oilseeds are carefully sorted on the basis of high-precision color recognition.

Roasting and pasteurizing

The NR roasting system is characterized by the fact it develops a good product flavor and ensures an optimal shelf life and uniform roasting degree. Especially the high oxidation resistance achieved has a highly beneficial effect on the shelf life of roasted hazelnuts, peanuts, almonds, and cashew nuts. In addition, a novel pasteurizing process for almonds efficiently reduces the germ count while leaving the visual appearance of the treated almonds unchanged and minimizing the water absorption capacity.



Dehulling

The need for gentle removal of the seed coat of hazelnuts without injuring the surface was the driving force behind the development of this hulling process, which uses compressed air.

Whole nuts – chopped nuts – nut paste

Depending on the specific application, the whole roasted nuts can be directly packaged under vacuum or be further processed. In the chopping process covering several breaking passes, gentle calibration is possible with minimum loss. As an alternative, an easy-to-use impact and shear mill may process the nuts into a very homogeneous and fine nut paste.



Other sweet paths.

Specialty and filling masses, compounds and rework.

Specialty and filling masses

Specialty masses are an outstanding addition to chocolate and produce particularly enjoyable sensations on the palate. Buhler offers proven solutions for processing marzipan, persipan & gianduja, nougat, and many other types of filling masses. Their recipes can, for example, be mixed, reduced, or liquefied as required by the specific plant. For flexible production with frequent recipe changes, the equipment of choice is the multifunctional twin-shaft mixer with exchangeable mixing tubs. Equipped with a cutter tool, lumpy raw materials or rework are processed into a homogeneous mass. The shelf life of articles with nut fillings is significantly increased, for example by seed precrystallization.

Compounds

For compound production, Buhler has developed a compact system for efficient blending & mixing and grinding by bead mill. As an alternative, fat masses can be produced by the two-stage refining process with subsequent liquefaction, with minimized product cross-contamination and high throughput capacity.

Rework solutions

Buhler offers you customized concepts for handling rework masses. We welcome your inquiries on handling, grinding, and mixing. Here, too, Buhler offers you solutions tailored to your specific needs.





Buhler – Your lifelong partner. Care from A to Z.

Unique in the world of chocolate: In 39 of its own affiliates and in 140 markets, you will find one of over 3000 Buhler experts on site, ready to advise you in your specialized your own technical and national language. Consistent spare parts and customer services guarantee maximum uptime of your plant and equipment.

Higher utility, easier operation, and outstanding performance are available to you through the retrofit packages offered by Buhler. Decide for yourself to what extent you wish to keep up with the rapid pace of technological change. From a higher level of automation to complete machine reconditioning, you have all the options. Every production line or process stage tailored to your specific needs is based on unique specifications. In every project, the knowledge required for achieving a strategic success position is applied jointly by your key experts and Buhler. Fully in line with the business philosophy of Buhler, you can count on absolute confidentiality every time we cooperate with you.

Putting your ideas into successful practice

You tell us your ideas, and Buhler will provide its vast expertise in engineering and process technology. You can benefit from excellently equipped technical laboratories at the various Buhler sites for developing and realizing your ideas in customized tests or for training your personnel. With its professional engineering services, Buhler transfers successful test results from the engineering laboratory to a highly efficient commercial scale.

Automation: The window to the process

To make high-quality products, recipe-compliant blends and trouble-free processes are required. At Buhler, customer specialists, product technologists, plant and equipment designers, service technicians, and automation specialists work hand in hand. This is the best guarantee for absolute process mastery and the resulting high uptime of your production systems.

The Buhler spirit. The crucial edge.

Credibility, healthy realism, a team spirit, and pleasure characterize collaboration with Buhler. What has been decided upon will be done – after all, Buhler can offer a rich trove of experience in executing demanding projects in addition to its enthusiasm for innovation. With Buhler teaming up with you, inspiration is transformed into an effective plan for future success. The plan is then turned into a reality – and into sustainable profits for both partners. Reliability means: Buhler will be around until everything is up and running to your entire satisfaction. And will return again every time you come up with new ideas.

Innovation power from a spirit of discovery

Buhler believes in the future of the cocoa and chocolate market and is committed to the continuous development of new technologies and knowledge. In this, the Chocolate & Cocoa business unit profits from the exchange of experience and knowledge among the different specialized sites and from synergies with other segments of the Buhler Technology Group, which is a market leader in numerous areas. Of course, Buhler also collaborates with leading research institutes.

Training and continuing education

Successes in new technologies and knowledge achieved over the decades flow constantly into the Group's comprehensive technology consulting and the training opportunities it offers to your production and maintenance personnel. Specialist training courses in process technology, plant and equipment maintenance, and electrical control systems are held either at Buhler in Switzerland or Germany, or in the form of customized training and continuing education programs at your own local site and on your equipment.

With a sure instinct for future trends: Buhler sets standards in the chocolate industry

- 2008** Almond pasteurizer
- 2008** Revolutionary depositing using flexible nozzles
- 2002** Market launch of seed precrystallization
- 1996** Patent applied for the Frisse conching tool
- 1992** Automatic system for measuring the product film thickness on five-roll refiner rolls
- 1984** Nut roasting system giving nuts superior oxidation resistance
- 1983** Launch of the two-stage chocolate refining process
- 1975** New NARS cocoa process from Barth
- 1956** First hydraulic five-roll refiner from Buhler
- 1935** First automatic coating system from Bindler
- 1900** Roaster for cocoa, nuts, coffee, and grain from Barth

Bühler Barth AG

D-71691 Freiberg, Germany
T +49 7141 705 0
F +49 7141 705 100
info@gw-barth.de
www.gw-barth.de

Richard Frisse GmbH

D-32107 Bad Salzuflen, Germany
T +49 5221 7705 0
F +49 5221 7705 11
info@frisse.de
www.buhlergroup.com

Bühler Bindler GmbH

D-51689 Bergneustadt, Germany
T +49 2261 4091 0
F +49 2261 4091 95
info@bindler.com
www.bindler.com

Bühler AG

CH-9240 Uzwil, Switzerland
T +41 71 955 11 11
F +41 71 955 35 82
sc.buz@buhlergroup.com
www.buhlergroup.com

