

Safe Food.
Clean Food.

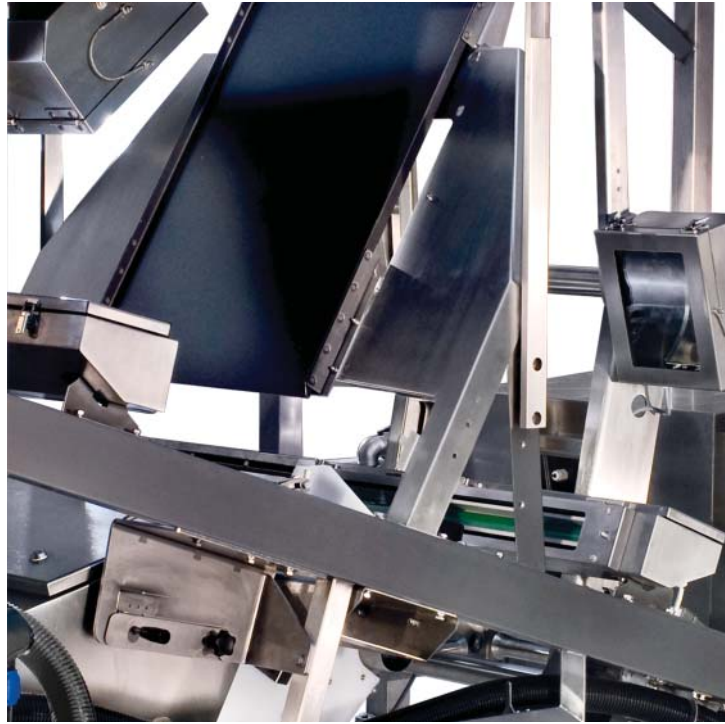

SORTEX E1C

Redefining concepts and setting standards. Engineered for precision sorting.

The latest addition to the successful range of optical sorters, the SORTEX E1C sets new standards in hygiene, precision sorting and consistent yield for the food processing industry. The SORTEX E1C truly reflects the Bühler tradition for innovation and leadership in technology, and with over 60 years of experience in the industry, Bühler continues to meet and exceed expectations.



Peanuts



Walnuts



Cashews



Pistachios



Beans



Seeds



Plastics



Dried Fruits

Fresh design concept.

Cutting edge technology enhances product quality.

Engineered to satisfy current hygiene requirements set by the food industry, particularly within the nut sector, the SORTEX E1C has a stainless steel frame and an open design construction which allows easy access for cleaning and thorough wash down.

Equipped with cutting edge technologies from Bühler - high-definition, custom-built cameras, broad-spectrum lighting, shape detection and high pressure ejectors; the SORTEX E1C delivers the highest yield of unrivalled quality.

Custom-built cameras, designed in-house:

A combination of visible cameras and InGaAs Technology

High resolution, custom built cameras can detect the subtlest of colour defects, resulting in an accurate distinction between good and defective product.

A wider range of hard-to-remove defects and foreign material, such as shell, sticks, stones, sclerotia etc., can be detected by combining InGaAs Technology with visible cameras.

Visible camera
frame capture



InGaAs Technology
frame capture

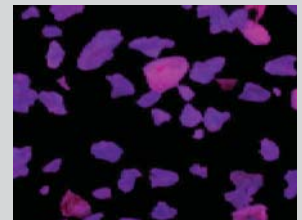

InGaAs Technology provides much better separation of good product from same colour foreign material, in comparison to the visible camera.

Broad Spectrum Lighting: Viewing a wider range of defects.





Broad spectrum lighting enables viewing of a wide range of defects. The system carries a selection of filter options, from blue to short-wave infrared (SWIR) wavelengths, to enable the detection of specific defects. For example, in the case of blanched peanuts, yellow spot defects and sticks of similar colour to the peanut itself. In today's markets, this is an essential feature for many different product applications.

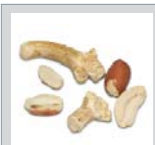

Broad spectrum lighting

PROfile (Shape) Technology: Adding a layer of assurance.

PROfile Technology improves sorting accuracy by distinguishing good product from foreign material - by its shape - even when these cannot be distinguished within the entire spectrum of visible and infra-red light. PROfile technology, which detects the size and shape features of the product, can be used in combination with colour, to improve the detection of defects.

	To remove sticks from peanuts		To remove butterballs from walnut halves		To separate over/under-length nuts		To recover wire from WEEE/ELV plastic residue
---	-------------------------------	---	--	---	------------------------------------	---	---

More and more. Intelligent features.

Minimum product breakage

A notable feature of the SORTEX E1C is the curved receptacle, which guides the good product down a gentle ski slope, preventing unnecessary product breakage.



Instant product changeover

The control program allows users to store settings for different sorting requirements, to enable instant changeover from one product to another. The filter changer allows the system to switch between different filter wavelengths automatically, as different product modes are selected.

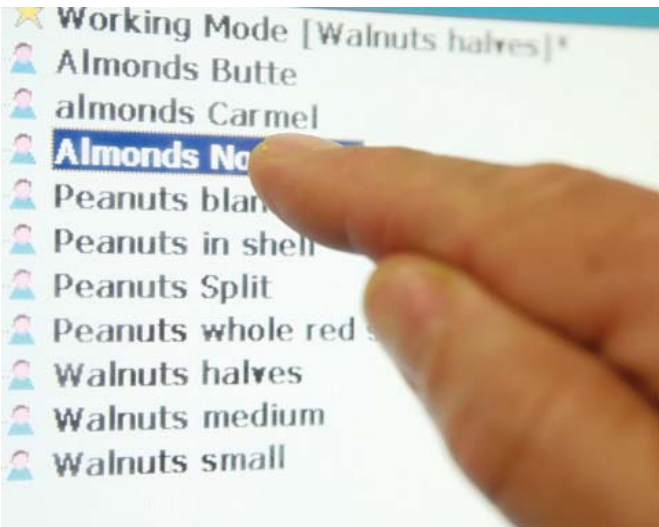

Improved product quality

The SORTEX E1C in-feed vibrator has a built-in air leg which removes dust and loose debris from the product immediately before the viewing area.

This feature significantly enhances the sort quality in both the accept and reject channels.



Climate Control System

The SORTEX E1C has a Climate Control System fitted to the camera boxes to ensure stable and reliable operation in extreme temperature ranges.

Cost of ownership

Inexpensive halogen lights are fitted for excellent product illumination and to provide low-cost of ownership.



Safe Food.
Clean Food.



SORTEX E1C Specifications.

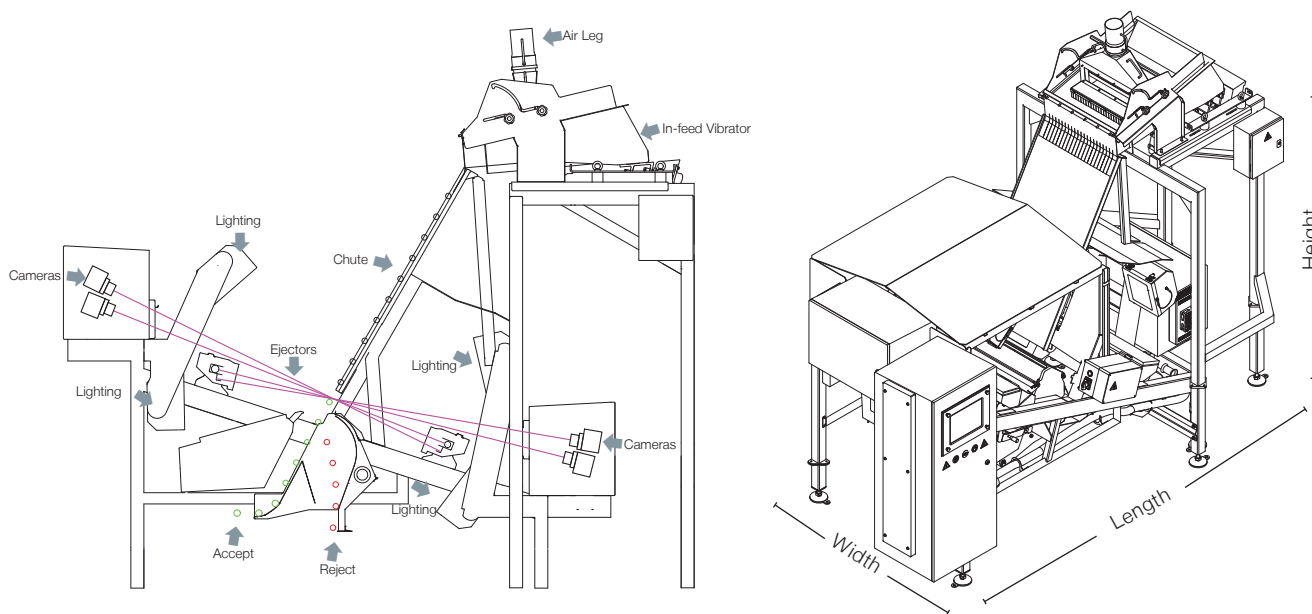

Technical details

	Power consumption (200-240 V; 50/60 Hz single phase)	Air requirements*
SORTEX E1C	2.5 kW (Total)	Typically 32 l/sec for colour sorting
Vibrator	1 kW (Total)	

* The compressed air consumption of the sorter varies depending upon throughput and input contamination

Dimensions and Weight

Machine (With Vibrator)	Width (mm, in)	Length (mm, in)	Height (mm, in)	Weight (kg, lbs)
Short Chute	1514, 60	3194, 126	2190, 86	680, 1500
Long Chute	1514, 60	3194, 126	2657, 105	680, 1500

Features

- Stainless steel construction and open design
- High resolution visible cameras
- Optional InGaAs Technology
- Halogen Lighting
- PROfile (Shape) Technology
- Climate Control System
- Air leg built into the in-feed vibrator

Benefits

- Hygienic operation and easy cleaning
- Detects and removes small and subtle colour defects and most foreign material
- Detection and removal of problematic foreign material
- A very stable solution giving flexibility in defect detection
- Allows additional removal of defective material
- Ensures consistent performance
- Improved handling of dusty products

SORTEX Customer Care.

Secure tomorrow's profits today.

Bühler's worldwide Customer Care organisation delivers the highest quality local support. The SORTEX Total Care and SORTEX Care programmes combine local support with a range of services, embracing the latest in communications technology.

Support Packages

GOLD

Ensure Maximum Uptime

Total Care Gold offers the most comprehensive support to ensure that your investment is fully protected. It promises maximum uptime and delivers proactive support of the highest quality. It is designed for those customers whose sorter is critical to production.

SILVER

Minimise Downtime

Total Care Silver ensures high quality focused services that maintain the sorter in optimum condition. The Total Care Silver package offers extensive service features that address sorter maintenance and guard against problems.

BRONZE

Essential Support

Total Care Bronze offers a valuable level of cost effective protection to areas of prime concern. Self-selectable service features can create a programme that best suits operational requirements.

SORTEX Customer Care Packages

SORTEX Total Care Gold, Silver, Bronze and Care packages allow customers to select a support service tailored to their exact operational needs. The components of each service are detailed below and customers can select those most appropriate. Contact your local Bühler Sortex representative for a quotation.



	Gold	Lite*	Silver	Lite*	Bronze**	SORTEX Care Plus**	SORTEX Care**
Anywhere Fault Alerts	■	■			■	■	
Anywhere Health Checks	■	■			■	■	
Wear Care (Wear Parts)	■	■	■	■	■		
Repair Care (Repair Parts)	■	■	■	■	■		
Ejector Care	■		■		■		
Repair Visits	■	■	■	■		■	■
Maintenance Visits	■	■	■	■		■	■
Operator training	■	■	■				

* For customers whose ejector service interval is more than 24 months.

** Any combination is available.

All contracts are available for different durations.



Buhler Sortex Ltd.
20 Atlantis Avenue
London E16 2BF
United Kingdom
T +44 20 7055 7777
F +44 20 7055 7700
www.buhlergroup.com

Buhler Sortex Inc.
2385 Arch-Airport Road, Suite 300
Stockton, CA 95206
USA
T 209 983 8400
F 209 983 4800
sortexsales@buhlergroup.com

